



IC-9100

The perfect COMBO,
without compromise



IC-9100

High Performance DSP for HF, 6m, 2m, and 70cm

IC-9100 Uses?

- **VHF/UHF/SHF***
 - EME
 - Satellite
 - SSB, CW, FM, D-STAR
 - Contesting
 - Perfect "Rover" rig
 - EmComm
- **HF**
 - Contesting
 - Rag Chewing
 - SSB, CW, RTTY, AM, FM, D-STAR
 - Digital modes (USB Port)
 - EmComm



*optional UX-9100 required

Double Conversion Superheterodyne

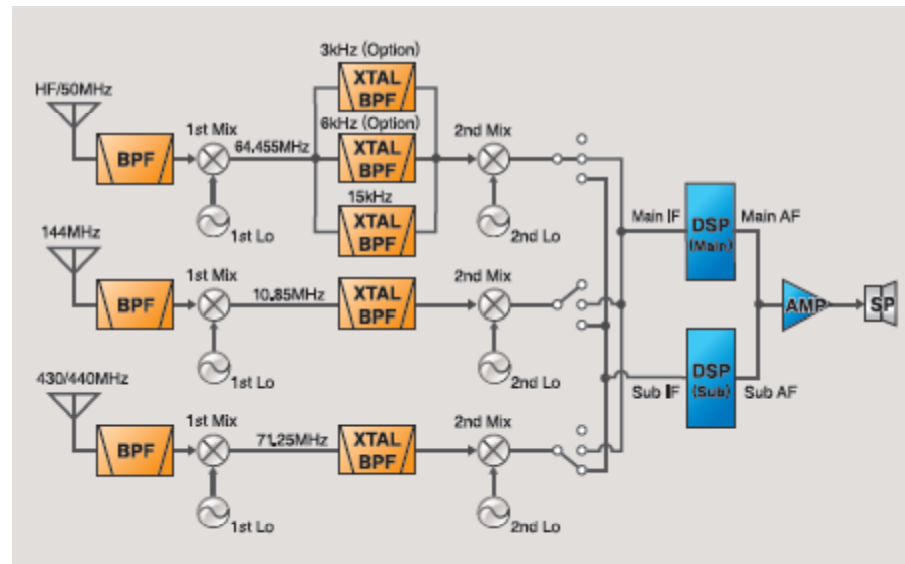

Icom's basic idea about the best receiver circuit is to reproduce high fidelity audio without internal distortion. Our answer to achieve this goal is to adopt a double conversion superheterodyne system*. The double conversion system simplifies the electronic circuitry and reduces the number of components which cause internal distortion. The digital signal processing (DSP) technologies and image rejection mixer make it possible to adopt this system.

* A triple conversion system is used for the 1200MHz band.

Independent receivers

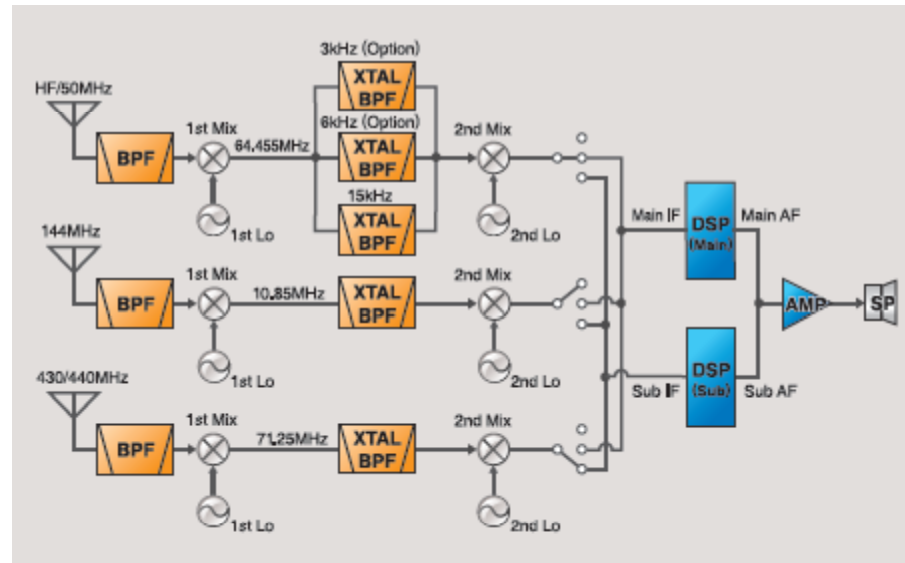

3 independent receiver circuits from the antenna connector to the second IF mixer (image rejection mixer). One for HF/6m, 2m, and 70cm. Simple receiver design reduce the number of IF stages in a receiver reduces the image and internal noise insertion points.

Installing the UX-9100 adds a fourth independent receiver.

Receiver Configuration

Main band \ Sub band	HF/50MHz band	144MHz band	430/440MHz band	1200MHz band
HF/50MHz	—	✓	✓	✓ *1
144MHz	✓	—	✓	✓ *1
430/440MHz	✓	✓	—	✓ *1
1200MHz	✓ *1	✓ *1	✓ *1	—

*1 With optional UX-0100.

Flexibility to listen to two receivers simultaneously. The chart above shows the simultaneous receive pairs.

High Performance DSP

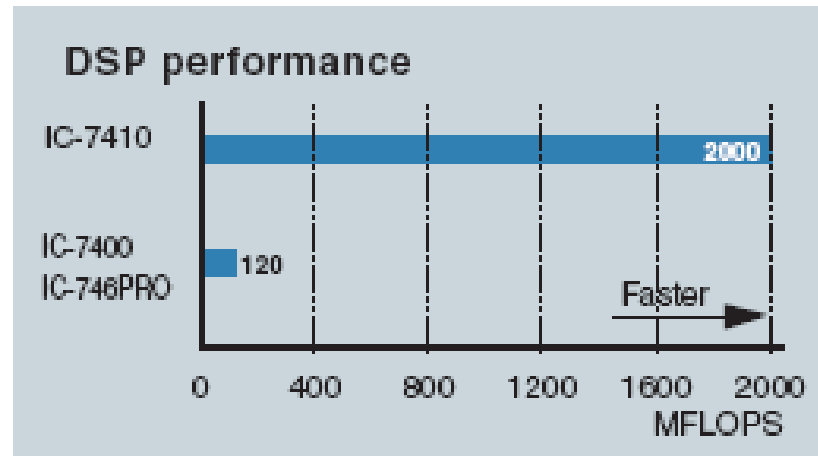

The IC-9100 employs a much higher speed DSP unit compared to the IC-746PRO/7400's DSP unit.

DSP Expertise



Employing the ADSP-21369 (DSP) and AK4620 (AD/DA) to provide a powerhouse of DSP performance in a HF/6m/2m/70cm Rig.

AGC Loop Management

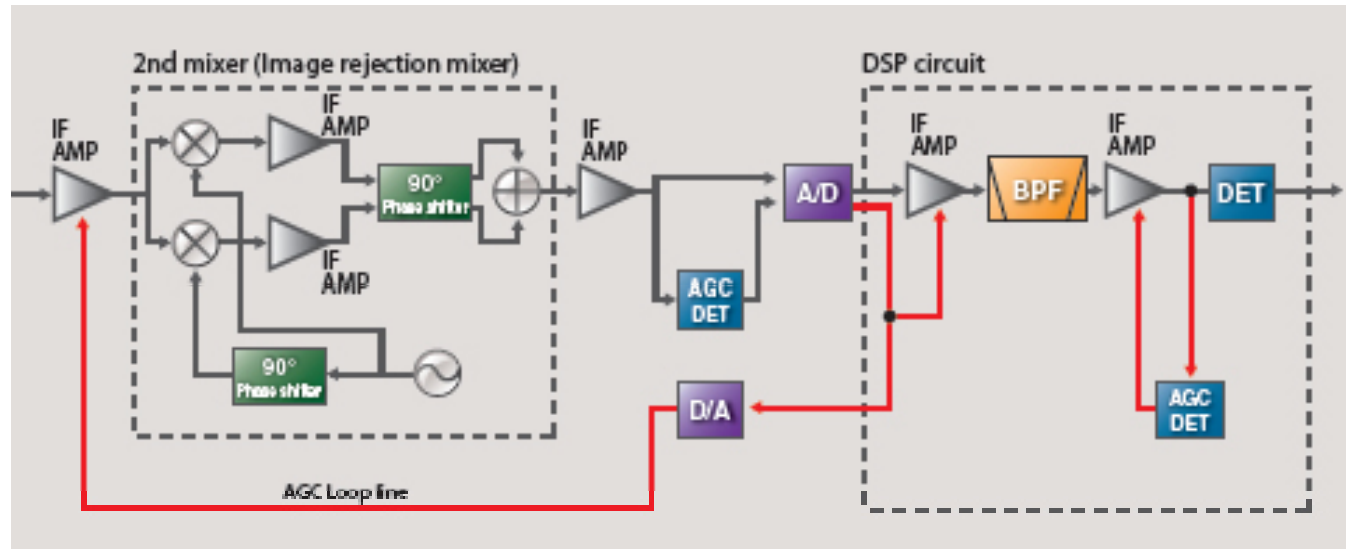

Digital IF filters, manual notch filter and other digital functions are incorporated in the AGC loop management controlled by the DSP unit. The AGC effectively works for the desired signal and rejects blocking by strong adjacent signals out of the filter passband. The AGC time constant presets (slow, medium and fast) give the flexibility and speed needed for working pile-ups. (HF/6m/2m/70/23cm*)

*Optional UX-9100 Required

DSP...NOT just for HF anymore*

(without a HF radio/Transverter)

- Digital “Create your own” IF filters
- Digital Twin Passband Tuning
- Noise reduction
- Noise blanker
- RF speech compressor
- Transmit bandwidth
- Manual notch filter
- Automatic notch filter
- (HF/6m/2/70cm/23cm*)

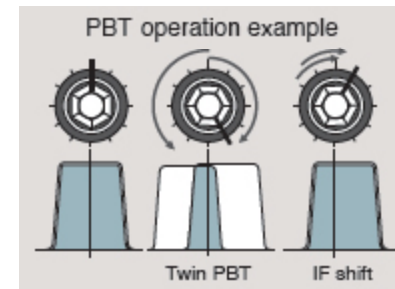

*optional UX-9100 required

HF/6m/2m 100W 70cm 75W



HF/50MHz FET



144MHz FET



430/440MHz FET

The use of high efficiency power amplifiers and the large heat sink provide stable output power, even during long periods of operation.



Heat sink

+30 dBm Third-Order Intercept point (IP3)

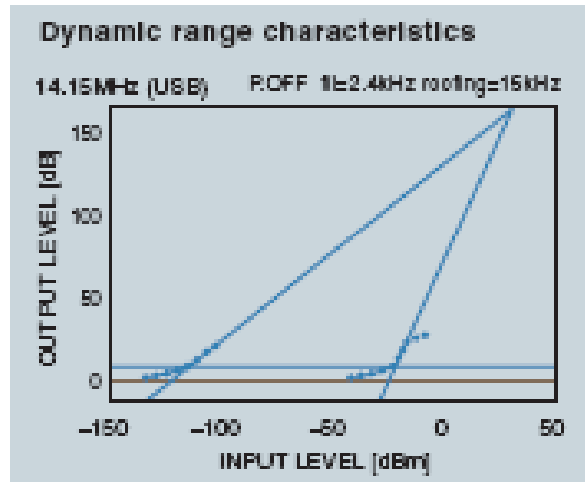

Icom's analog RF circuit experience over a number of years combined with the latest DSP software technology results in +30dBm IP3 equivalent to the IC-7600.



GPS???



In addition to the D-STAR functions of D-PRS®, the IC-9100 will display the current GPS location along with your grid square information at a push of a button. Perfect for “Rover” operations in a VHF/UHF Contest!

Three 1st IF Filters (3/6/15kHz)

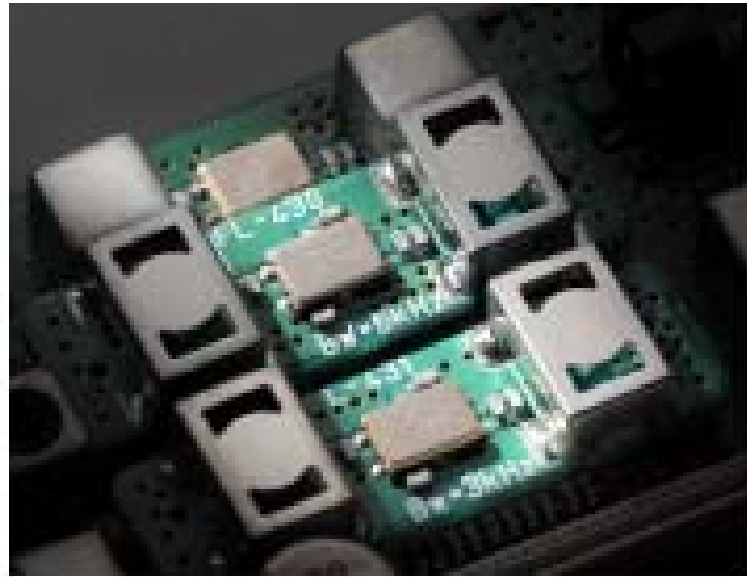

The IC-9100 comes with a built-in 15kHz 1st IF filter and can accept up to two optional filters (3kHz FL-431 and 6kHz FL-430).

Large, Multi-Function LCD

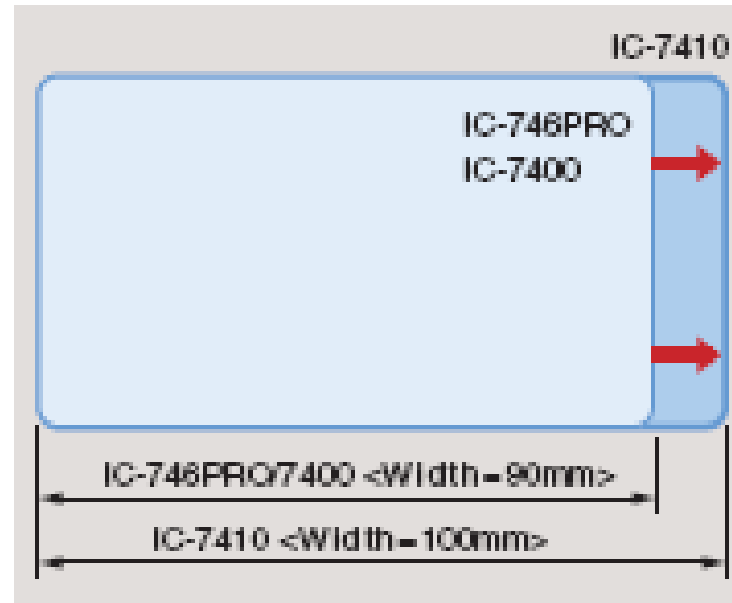

The large multi-function LCD shows frequency, 9-character channel name, channel number, multi functional meter (includes S-meter, RF output, SWR and ALC level).

Rig Control



The IC-9100 has a standard type B USB connector for rig control as well as modulation input, audio output, RTTY demodulator output and CI-V command can be controlled via the USB cable.